

DXN MARKETING PLAN



Definition of Terms

PV	Point Value, for qualification and status.
SV	Sales Value, for calculation of Bonus and Incentive.
Personal Point Value (PPV) / Personal Sales Value (PSV)	Total PV/SV generated from all personal cash bills transacted in a month.
Personal Group Point Value (PGPV) / Personal Group Sales Value (PGSV)	Total PV/SV generated in a month by all downline distributors within personal group (ie. excluding breakaway QSAs) and own PPV/PSV.
Diamond Group Point Value (DGPV) / Diamond Group Sales Value (DGSV)	Total PV/SV generated in a month by all downline distributors within your diamond group (ie. excluding breakaway QSDs) and own PPV/PSV.
Qualified Star Agent (QSA)	Any SA who maintains 100PPV and 300 PGPV in a month.
Qualified Star Diamond (QSD)	Any Diamond who qualifies for 37% Star Group Bonus.
Travel Seminar Qualifier	Any SA and above who meets the Yearly Travel Seminar Incentive Points (TSIP) Quota set for the year.

Introduction of Remuneration

1. Retail Profit

15% - 25%

2. Bonus (71%) and Cash Incentive (RM8,050)

a) <i>Group Bonus</i>	6% - 21%
b) <i>Star Group Bonus</i>	25% - 37%
c) <i>Development Bonus</i>	15%
d) <i>Development Bonus</i>	2%
e) <i>Leadership Bonus</i>	15%
f) <i>Travel Seminar Incentive</i>	2%
g) <i>One Time HP Cash Incentive</i>	RM1,050
h) <i>One Time Overseas Trip Cash Incentive</i>	RM7,000

Distributor		Age 18 years and a sponsor
Star Agent (SA)		Achieves accumulated Group Sales of 4,500 PV
Star Ruby (SR)		Sponsors 3 First Generation Star Agent (SA)
Star Diamond (SD)		With 6 First Generation Star Agents (SA) + qualifies for 37% Star Group Bonus
Executive Star Diamond (ESD)		Star Diamond who sponsors 1 Star Diamonds*
Senior Star Diamond (SSD)		Star Diamond who sponsors 2 Star Diamonds*
Executive Senior Star Diamond (ESSD)		Star Diamond who sponsors 3 Star Diamonds*
Double Diamond (DD)		Star Diamond who sponsors 4 Star Diamonds*
Executive Double Diamond (EDD)		Star Diamond who sponsors 5 Star Diamonds*
Triple Diamond (TD)		Star Diamond who sponsors 6 Star Diamonds*
Executive Triple Diamond (ETD)		Star Diamond who sponsors 7 Star Diamonds*
Gold Diamond (GD)		Star Diamond who sponsors 8 Star Diamonds*
Executive Gold Diamond (EGD)		Star Diamond who sponsors 9 Star Diamonds*
Crown Diamond (CD)		Star Diamond who sponsors 10 Star Diamonds*
Executive Crown Diamond (ECD)		Star Diamond who sponsors 11 Star Diamonds*
Senior Crown Diamond (SCD)		Star Diamond who sponsors 12 Star Diamonds*
Executive Senior Crown Diamond (ESCD)		Star Diamond who sponsors 13 Star Diamonds*
Double Crown Diamond (DCD)		Star Diamond who sponsors 14 Star Diamonds*
Executive Double Crown Diamond (EDCD)		Star Diamond who sponsors 15 Star Diamonds*
Triple Crown Diamond (TCD)		Star Diamond who sponsors 16 Star Diamonds*
Executive Triple Crown Diamond (ETCD)		Star Diamond who sponsors 17 Star Diamonds*
Gold Crown Diamond (GCD)		Star Diamond who sponsors 18 Star Diamonds*
Executive Gold Crown Diamond (EGCD)		Star Diamond who sponsors 19 Star Diamonds*
Crown Ambassador (CA)		Star Diamond who sponsors 20 Star Diamonds*

* As per dynamic compression.

1. Retail Profit (15% - 25%)

Direct profit for distributors is when they sell DXN products to non-DXN members. Retail profit is the difference between distributor price and retail price.

2. Group Bonus (6% - 21%)

To be entitled for this Group Bonus, you need to maintain 100PPV each month.

Accumulated Group PV	Bonus
4,500 and above	21%*
3,250	18%
2,000	15%
1,000	12%
300	9%
100	6%

* If a Star Agent (21%) maintains 100PPV and 300PGPV **, he will become a Qualified Star Agent (25%).

3. Star Group Bonus (25% -37%)

To be entitled for this Star Group Bonus, you must be a SA and maintain 100PPV and 300 PGPV** (QSA).

No. of SA (1st Generation)	No. of Qualified SA Lines	DGPV	Bonus
6	-	5,000	37%
	4	2,500	
5	-	3,000	35%
	4	2,000	
4	4	-	33%
3	3	-	31%
2	2	-	29%
1	1	-	27%
0	0	-	25%

**PGPV is inclusive of personal PV (i.e. 100PPV + 200 non-QSA group PV).

For SSD and above, if the number of QSD is more than one, then the DGPV can be borrowed from one of the QSD and the number of the QSD will be reduced by one.



4. Development Bonus (15%)

To be entitled for this Development Bonus, you must be a SA and maintain 100 PPV and 300 PGPV**(QSA)

Level of Qualified SA	Bonus
1st Level	5%
2nd Level	4%
3rd Level	3%
4th Level	2%
5th Level	1%

** PGPV is inclusive of personal PV (i.e. 100 PPV + 200 non-QSA group PV).

5. International Profit Sharing (2%)

To be entitled for this International Profit Sharing (IPS) you must be a Qualified Star Diamond (QSD).

$$\text{IPS Fund} = \text{Overall Company's Sales in SV} \times 2\%$$

Your IPS entitlement

$$= \text{IPS Fund} \times \frac{\text{Your IPS Point for the month}}{\text{Total IPS Point for all Qualified Star Diamond and above}}$$

Your IPS Point calculation:

Level of Qualified SD	IPS Point
Personal	DGSV X 100%
1st Level QSD (L1)	+ L1 DGSV X 50%
2nd Level QSD (L2)	+ L2 DGSV X 40%
3rd Level QSD (L3)	+ L3 DGSV X 30%
4th Level QSD (L4)	+ L4 DGSV X 20%
5th Level QSD (L5)	+ L5 DGSV X 10%



6. Leadership Bonus (15%)

To be entitled for this Leadership Bonus, you must be a Qualified Star Diamond (QSD).

No. of Qualified SD Lines	1	2	3	4	5
1st Level QSD's DGSV	5%	5%	5%	5%	5%
2nd Level and below QSD's (till 1st level of next qualifier)	-	3%	4.8%	5.8%	6.5%
Minimum DGSV needed to Guarantee upline ('000)	2.5	5	7.5	10	10

No. of Qualified SD Lines	6	7	8	9	10
1st Level QSD's DGSV	5%	5%	5%	5%	5%
2nd Level and below QSD's (till 1st level of next qualifier)	7.1%	7.6%	8%	8.3%	8.5%
Minimum DGSV needed to Guarantee upline ('000)	10	10	10	10	10

No. of Qualified SD Lines	11	12	13	14	15
1st Level QSD's DGSV	5%	5%	5%	5%	5%
2nd Level and below QSD's (till 1st level of next qualifier)	8.7%	8.9%	9.1%	9.3%	9.5%
Minimum DGSV needed to Guarantee upline ('000)	10	10	10	10	10

No. of Qualified SD Lines	16	17	18	19	20
1st Level QSD's DGSV	5%	5%	5%	5%	5%
2nd Level and below QSD's (till 1st level of next qualifier)	9.6%	9.7%	9.8%	9.9%	10%
Minimum DGSV needed to Guarantee upline ('000)	10	10	10	10	10



7. Travel Seminar Incentive (2%)

This Travel Seminar Incentive (TSI) shall be used by the qualifier for the travel seminar organised by the Company only. It is not exchangeable for cash and also not transferable. A qualifier may claim up to maximum Travel Seminar Fare against his/her TSI fro two (2) if married.

$$\text{Travel Seminar Incentive Fund} = \text{Company's Annual Sales in SV} \times 2\%$$

* To be shared as below:

- i) 50% of the Travel Seminar Incentive Fund (TSIF) to be shared amongst all SA and above who met the YEARLY TSIP QUOTA set for the year.
- ii) 50% of the Travel Seminar Incentive Fund (TSIF) to be shared amongst all SD and above who met the YEARLY TSIP QUOTA set for the year.

a) Travel Seminar Incentive for SA Qualifier (TSIsa)

$$\text{TSIsa} = 50\% \times \text{TSIF} \times \frac{\text{Accumulated TSIP* for a SA Qualifier}}{\text{Total Accumulated TSIP for all SA Qualifiers}}$$

* Travel Seminar Incentive Point (TSIP) will be calculated monthly based on the following formula and to be accumulated for a year:

Level of Qualified SA	Monthly Travel Seminar Incentive Point (TSIP)
Personal	PGSV X 100%
1st Level QSA (L1)	+ L1 PGSV X 50%
2nd Level QSA (L2)	+ L2 PGSV X 40%
3rd Level QSA (L3)	+ L3 PGSV X 30%
4th Level QSA (L4)	+ L4 PGSV X 20%
5th Level QSA (L5)	+ L5 PGSV X 10%

b) Travel Seminar Incentive for SD Qualifier (TSIsd)

$$\text{TSIsd} = 50\% \times \text{TSIF} \times \frac{\text{Accumulated TSIP* for a SD Qualifier}}{\text{Total Accumulated TSIP for all SD Qualifiers}}$$

* Travel Seminar Incentive Point (TSIP) will be calculated monthly based on the following formula and to be accumulated for a year:

Level of Qualified SD	Monthly Travel Seminar Incentive Point (TSIP)
Personal	DGSV X 100%
1st Level QSD (L1)	+ L1 DGSV X 50%
2nd Level QSD (L2)	+ L2 DGSV X 40%
3rd Level QSD (L3)	+ L3 DGSV X 30%
4th Level QSD (L4)	+ L4 DGSV X 20%
5th Level QSD (L5)	+ L5 DGSV X 10%



8. Hand Phone Cash Incentive (RM1,050) - One Time Only

When you have 3 immediate SA who achieved 6,000 Accumulated GPV, then you will be entitled to receive this **One Time** Hand Phone Cash Incentive amounting to RM1,050.

*Only personally sponsored downlines counted.



9. Overseas Trip Cash Incentive (RM7,000) - One Time Only

When you have 5 immediate downlines who have received their Hand Phone Cash Incentive, then you will be entitled to receive this **One Time** Overseas Trip Cash Incentive amounting to RM7,000.

*Only personally sponsored downlines counted.



1. Retail Profit (15%-25%)

Direct profit for distributors is when they sell DXN products to non-DXN members. Retail profit is the difference between distributor price and retail price.

Example:

If you sell one bottle of RG-30 to a non-DXN member, you will earn the retail profit as below:

One bottle of RG-30	
Distributor Price	RM25.00
Retail Price	RM30.00

Therefore,

Retail Price - Distributor Price = Retail Profit
RM30 - RM25 = RM5.00

YOUR retail profit is RM5.00 (20% from distributor's price)

Minimum monthly Personal PV required for bonus entitlement (100PV).

* Example 1

PRODUCTS	PV	SV
RG 90	51.50	51.50
GL 90	36.50	36.50
Spirulina (120's)	20.00	20.00
TOTAL	108.00	108.00

* Example 2

PRODUCTS	PV	SV
RG 90	51.50	51.50
GL 90	36.50	36.50
Lingzhi Coffee 3 in 1	9.50	9.50
Ganzhi Toothpaste	5.75	5.75
TOTAL	103.25	103.25



* Assume 1PV = 1SV for all the following Bonuses and Incentives calculations.

2. Group Bonus (6%-21%)

CASE 1

If in the first month you have acquired 100PV and sponsored 3 new distributors with 500PV each:

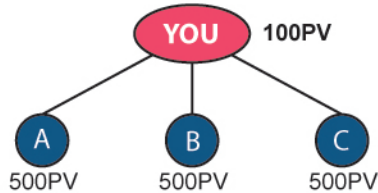

$$\begin{aligned}
 \text{Personal PV/SV (PPV/PSV)} &= 100\text{PV/SV} \\
 \text{Personal Group PV/SV (PGPV/PGSV)} &= 1,600\text{PV/SV} \\
 \text{Your Group Bonus} &= (1,600\text{SV} \times 12\%) - (500\text{SV} \times 9\%) \\
 &= (500\text{SV} \times 9\%) - (500\text{SV} \times 9\%) \\
 &= \text{RM}192 - \text{RM}45 - \text{RM}45 - \text{RM}45 \\
 &= \text{RM}57.00
 \end{aligned}$$

Therefore:

Your Group Bonus is RM57.00 and Group Bonus for A, B and C is RM45.00 each.

CASE 2

If YOU have acquired 60PV and each one of your downline achieved 500PV:

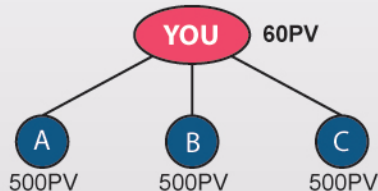

$$\begin{aligned}
 \text{Personal PV/SV (PPV/PSV)} &= 60\text{PV/SV} \\
 \text{Personal Group PV/SV (PGPV/PGSV)} &= 1,560\text{PV/SV}
 \end{aligned}$$

You are not qualified to receive any bonus because your Personal PV is less than 100 PPV. To qualify for Group Bonus, YOU must have a minimum of 100PPV.

1. Star Group Bonus (25%-37%)

CASE 1

If YOU are a Star Ruby (SR) and above sponsored 3 Star Agents (SA) and 2 distributors:

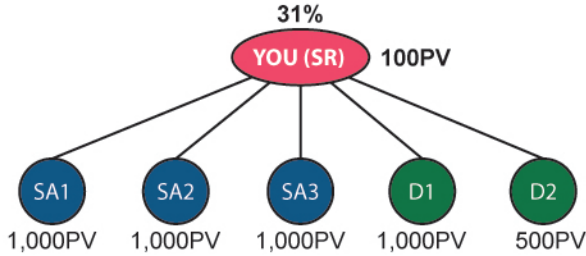

Personal PV/SV (PPV/PSV) = 100PV/SV
 Personal Group PV/SV (PGPV/PGSV) = 1,600PV/SV

Your Star Group Bonus = (4,600SV X 31%) - (1,000SV X 25%)
 - (1,000SV X 25%) - (1,000SV X 25%)
 - (1,000SV X 12%) - (500SV X 9%)
 = RM1,426 - RM250 - RM250
 - RM250 - RM120 - RM45
 = **RM511.00**

Therefore:

Your Star Group Bonus is RM511.00.
 SA1, SA2 and SA3 will earn RM250.00 each.
 Group Bonus for D1 is RM120.00 and D2 is RM45.00



CASE 2

If YOU are a Star Diamond with **6 SA** (1st Generation), 100PPV and 400 PGPV. At the same time, YOU have some downlines with the status of Star Ruby (SR) and Star Agent (SA) who have at least 100PPV.

The Star Group Bonus entitlement (%) for YOU and your downlines will be as follow:

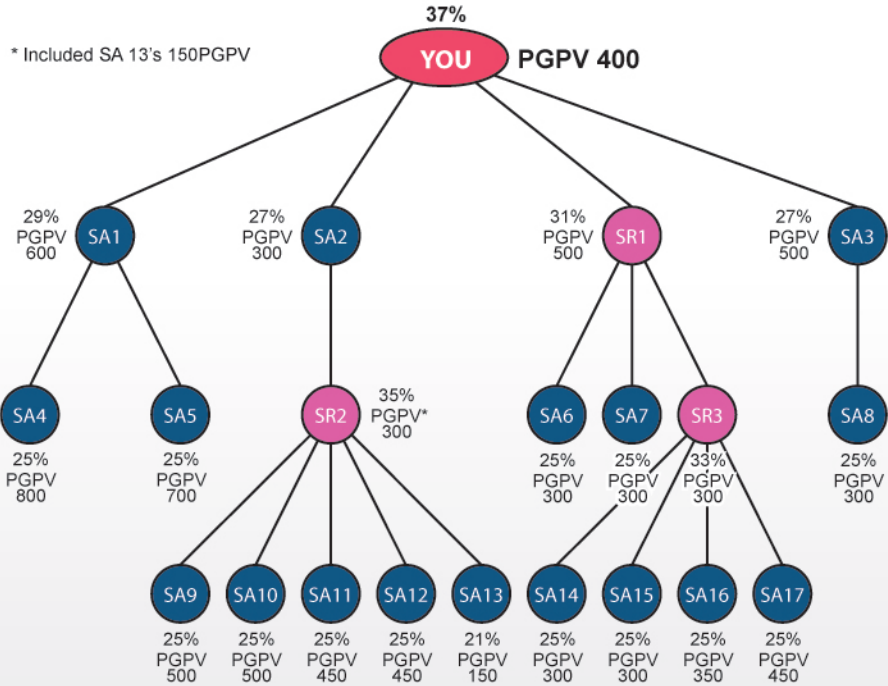

Star Group Bonus (%)

	Status	No of Qualified SA Lines	PPV	PGPV	DGPV	SGB entitlement (%)
YOU	SD	4	100	400	8,600	37%
SA1	SA	2	100	600		29%
SA2	SA	1	100	300		27%
SR1	SR	3	100	500	2,800	31%
SR2	SR	4	100	300	2,200	35%
SR3	SR	4	100	300	1,700	33%
SA4	SA	0	100	800		25%
SA13	SA	0	100	150		21%

CASE 3

If YOU are a Star Ruby (SR) with 5 SA (1st Generation), 1000PPV and 500PGPV. At the same time, YOU have downlines with the status of Star Ruby (SR) and Star Agent (SA). Some of the SR or SA are inactive (i.e. SA1, SA2, SA5 & SR):

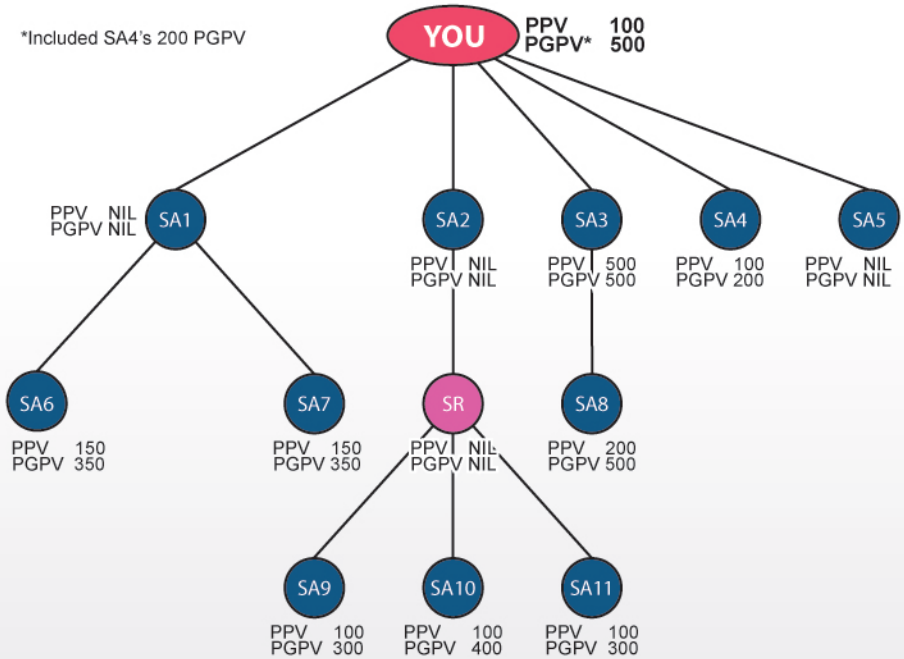

Therefore:

YOU are entitled to 35% of Star Group Bonus even you have only 3 qualified SA lines. It is because YOU have 5SA (1st Generation) and obtained 3,200 DGPV.

4. Development Bonus (15%)

CASE 1

For Development Bonus, if YOU are a Star Ruby (SR) and have downlines as below:

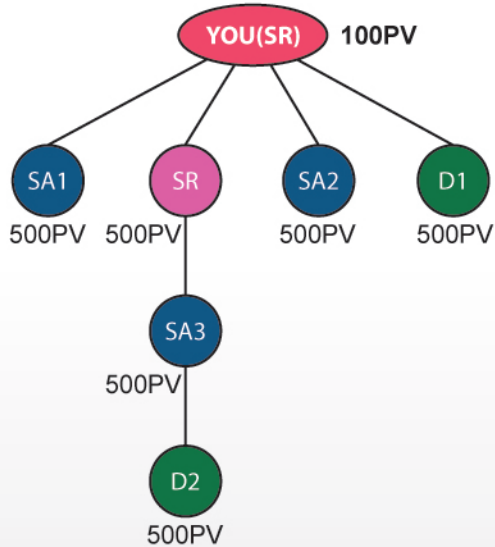

Personal PV/SV (PPV/PSV) = 100PV/SV
Personal Group PV/SV (PGPV/PGSV) = 600PV/SV

Your Development Bonus = $(1,500SV \times 5\%) + (1,000SV \times 4\%)$
= RM75 + RM40
= **RM115.00**

Therefore:
Your Development Bonus is RM115.00.

CASE 2

For Development Bonus, if YOU are a Star Ruby (SR) and have downlines as below:

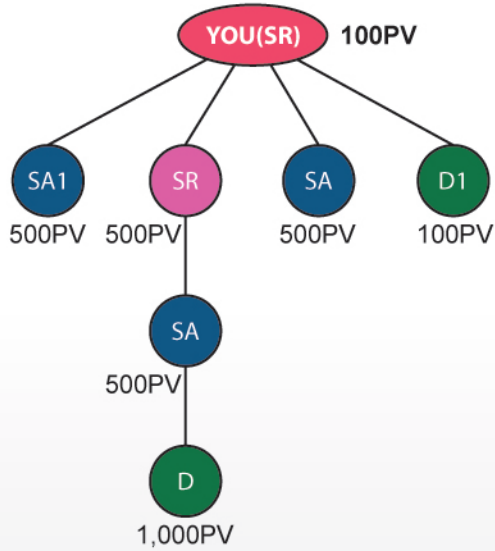

Personal PV/SV (PPV/PSV) = 100PV/SV
 Personal Group PV/SV (PGPV/PGSV) = 200PV/SV

Therefore:
 YOU are not qualified to earn the development bonus because your Personal Group PV is less than 300 PV.

5. International Profit Sharing (2%)

EXAMPLE

YOU are a Senior Star Diamond (SSD) and have downlines of Star Diamond (SD) and above.

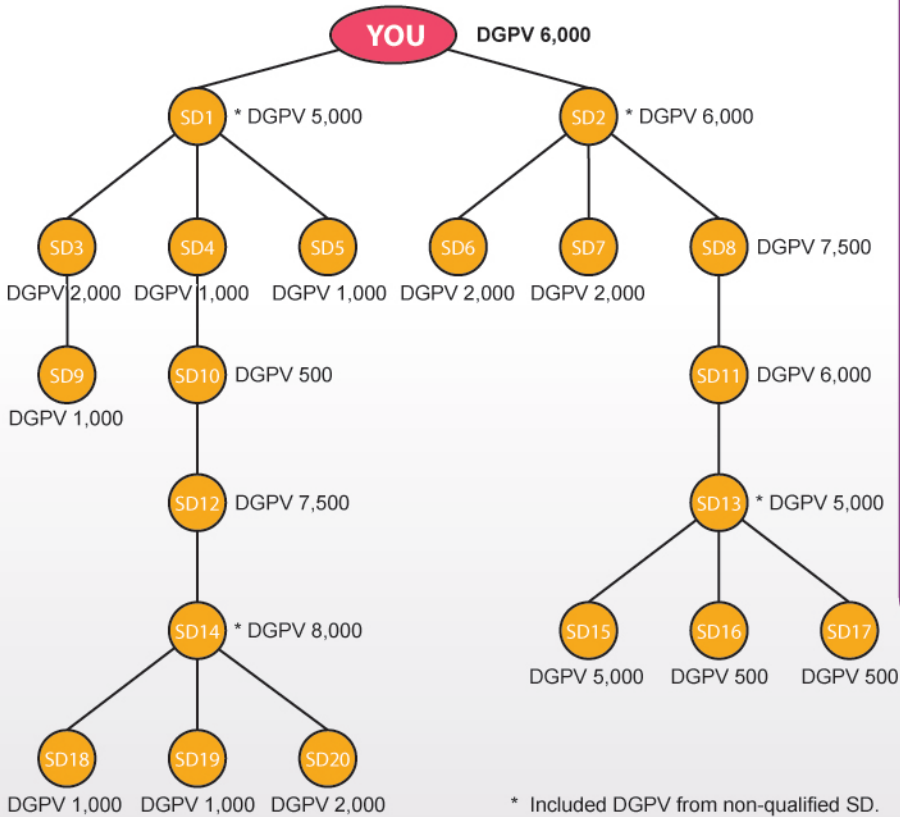

Non-qualified SD : SD3, SD4, SD5, SD6, SD7, SD9, SD10, SD16, SD17, SD18, SD19 & SD20

QUalified SD : YOU, SD1, SD2, SD8, SD11, SD12, SD13, SD14 & SD15

Assumption: -

- i) 1 PV equals to 1 SV.
- ii) There are 68 Star Diamonds and above in the company and the Total IPS Point is 500,000 points.
- iii) Total company's sales for that particular month is 2,000,000 SV.

IPS Point for YOU:

YOU

- 1st Level: SD1 + SD2
- 2nd Level: SD12 +SD8
- 3rd Level: SD14 + SD11
- 4th Level: SD13
- 5th Level: SD15

DGSV

- 6,000 X 100%
- 11,000 X 50%
- 15,000 X 40%
- 14,000 X 30%
- 5,000 X 20%
- 5,000 X 10%

IPS points

- = 6,000
- = 5,500
- = 6,000
- = 4,200
- = 1,000
- = 500

YOUR Total IPS Point

23,200

Therefore:

YOUR International Profit Sharing

$$= 2\% \times 2,000,000\text{SV} \times \frac{23,200 \text{ pts}}{500,000 \text{ pts}}$$

= RM1,856.00



6. Leadership Bonus (15%)

CASE 1

YOU are an Executive Senior Star Diamond (ESSD) and have qualified for 37% Star Group Bonus.
 Every Circle (from A1 to C6) represents a SD and above.
 All SDs have qualified for 37% Star Group Bonus.

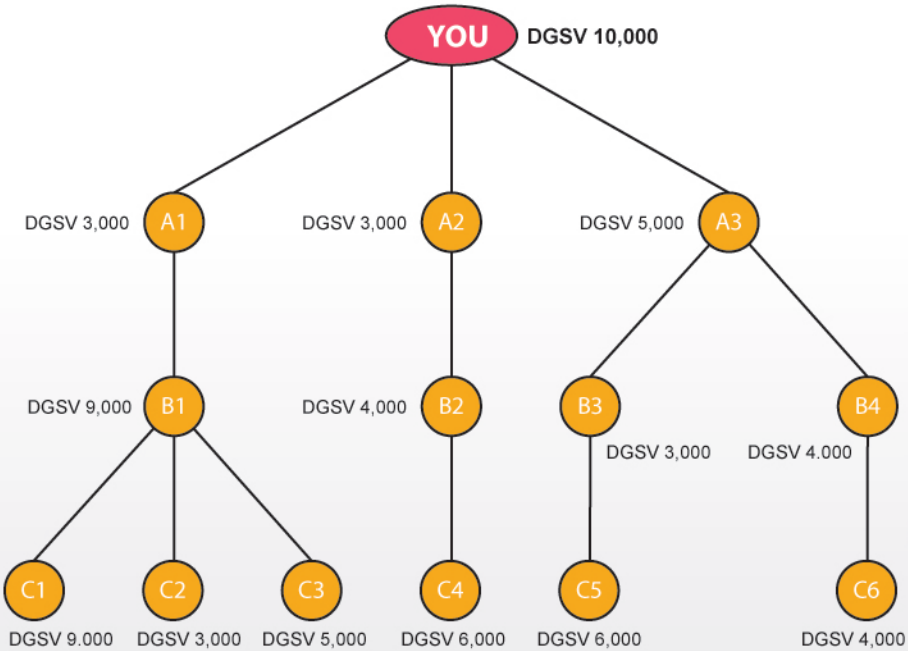

YOUR Leadership Bonus:

1st Level qualified SD:

$$A1 + A2 + A3 = 11,000\text{SV} \times 5.0\% = \text{RM } 550$$

2nd Level and below qualified SD:

$$B1 + C1 + C2 + C3 + B2 + C4 + B3 + B4 = 43,000\text{SV} \times 4.8\% = \text{RM}2,064$$

$$C5 + C6 = 10,000\text{SV} \times 1.8\% = \text{RM } 180$$

YOUR Leadership Bonus

RM2,794

CASE 2

YOU are an Executive Double Diamond (EDD) and have qualified for 37% Star Group Bonus.
 Every Circle (from A1 to C6) represents a SD and above.
 All SDs have qualified for 37% Star Group Bonus with the exception of A1,A2, A5 & B5

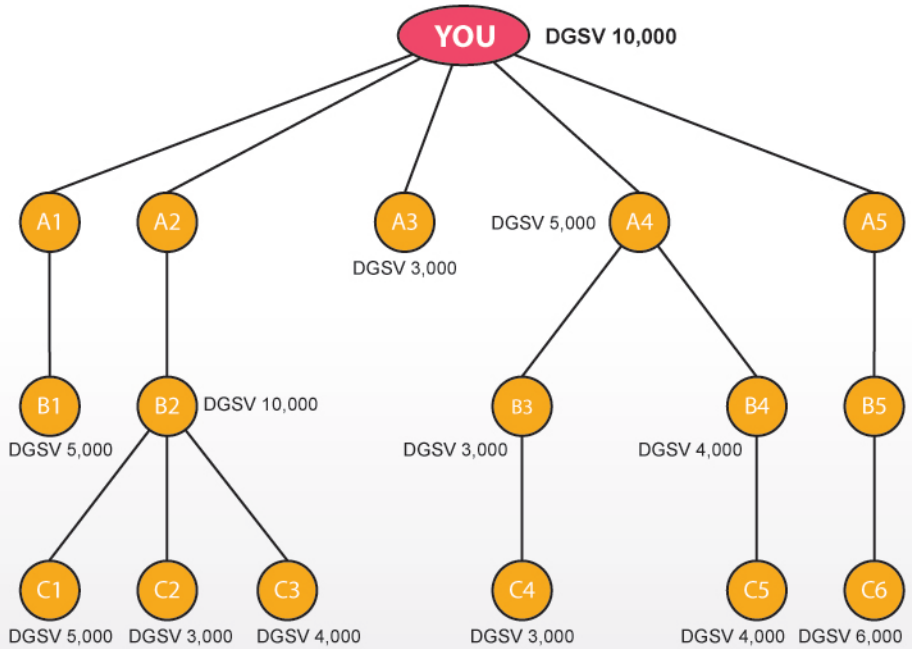

YOUR Leadership Bonus:

1st Level qualified SD:
 B1 + B2 + A3 + A4 + C6

= 29,000SV X 5.0% = RM1,450

2nd Level and below qualified SD:
 C1 + C2 + C3 + B3 + B4
 C4 + C5

= 19,000SV X 6.5% = RM1,235
 = 7,000SV X 3.5% = RM 245

YOUR Leadership Bonus

RM2,930

6. Leadership Bonus (15%)

CASE 3

YOU are an Executive Double Diamond (EDD) and have qualified for 37% Star Group Bonus. Every Circle (from A1 to C6) represents a SD and above. All SDs have qualified for 37% Star Group Bonus with the exception of A1, A2, A5 & B5.

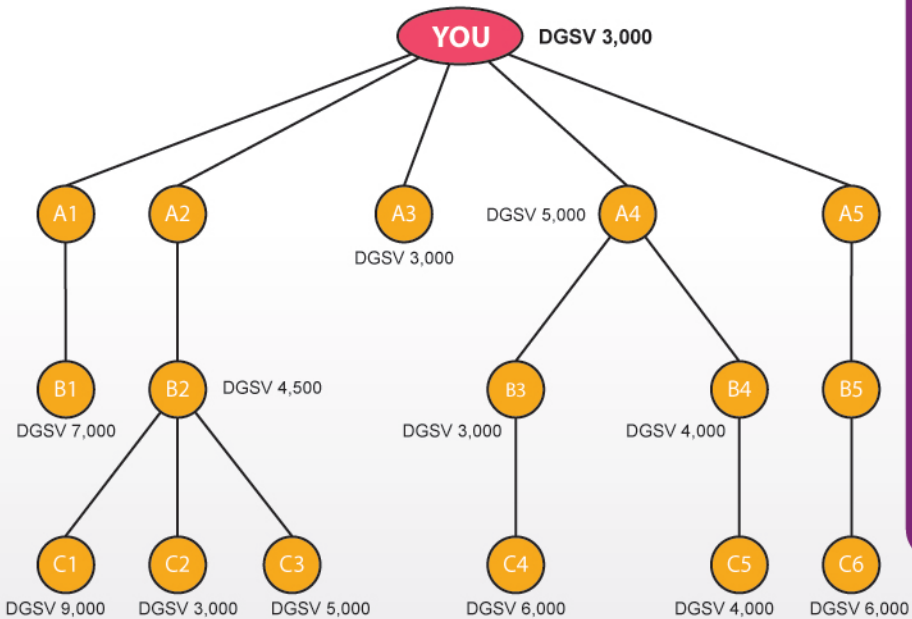

YOUR Leadership Bonus:

1st Level qualified SD:

B1 + B2 + A3 + A4 + C6

= 25,500SV

Add: Guarantee from Downline (B2)

= 3,000SV

Less: Guarantee Upline (YOU)

= (7,000SV)

21,500SV X 5.0% = RM1,075

2nd Level and below qualified SD:

C1 + C2 + C3 + B3 + B4

= 24,000SV

Less: Guarantee Upline (B2)

= (3,000SV)

21,000SV X 6.5% = RM1,365

C4 + C5

= 10,000SV X 3.5%

= RM 350

YOUR Leadership Bonus

RM2,790

* YOU need to guarantee upline 10,000 DGSV.

* B2 need to guarantee upline 7,500 DGSV.

CASE 4

YOU are a Crown Ambassador (CA) and have 20 first generation Crown Ambassadors (CAs) with 10,000DGSV each. All CAs have 20 Qualified SDs with 10,000 DGSV each.

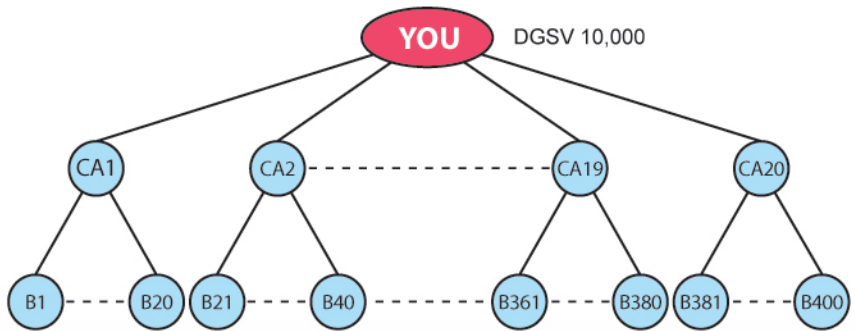

Therefore:

Your Leadership Bonus

1st Level Qualified SD: $10,000\text{DGSV} \times 20 \times 5\%$	= RM 10,000
2nd Level Qualified SD: $10,000\text{DGSV} \times 400 \times 10\%$	= RM400,000
	RM410,000

7. Travel Seminar Incentive (2%)

The company will allocate 2% of company's Annual Sales in SV as the Travel Incentive Fund. It will be shared amongst the SA Qualifiers & SD Qualifiers and used to subsidise the travel seminar organised by the Company only.

Assumption:-

- * Company Annual Sales is 18,000,000SV.
- * Travel Seminar Incentive Fund = 2% X 18,000,000SV
= **RM360,000**

A) Travel Seminar Incentive for SA Qualifiers.

Assumption:-

- i Total Accumulated TSIP for all SA Qualifiers is 800,000 points.
- ii YOUR Accumulated TSIP as a SA Qualifier is 12,000 points.
- iii Yearly TSIP QUOTA for SA is 10,000 points.
- iv Estimated cost of Travel Seminar for SA Qualifier is RM1,500/pax.

Therefore:

Your Travel Seminar Incentive as SA Qualifier

$$= 50\% \times \text{RM}360,000 \times \frac{12,000 \text{ pts}}{800,000 \text{ pts}} = \text{RM}2,700$$

Note: Your TSI is more than enough to pay for one person to attend the Travel Seminar. So, you can either go for this Travel Seminar by yourself without any cash refund for the excess incentive or you may bring along your spouse by paying additional RM300 as the short amount for the fare of two.

B) Travel Seminar Incentive for SD Qualifiers.

Assumption:-

- i Total Accumulated TSIP for all SD Qualifiers is 1,000,000 points.
- ii YOUR Accumulated TSIP as a SD Qualifier is 28,000 points.
- iii Yearly TSIP QUOTA for SD is 25,000 points.
- iv Estimated cost of Travel Seminar for SD Qualifier is RM2,500/pax.

Therefore:

Your Travel Seminar Incentive as SA Qualifier

$$= 50\% \times \text{RM}360,000 \times \frac{28,000 \text{ pts}}{1,000,000 \text{ pts}} = \text{RM}5,040$$

Note: Your TSI is more than enough to pay for two persons to attend the Travel Seminar. So, you can go for this Travel Seminar with your spouse. There is no cash refund for any excess incentive.

8. One Time Hand Phone Cash Incentive

EXAMPLE

After you have sponsored 3 immediate SA who achieved 6,000 Accumulated GPV.

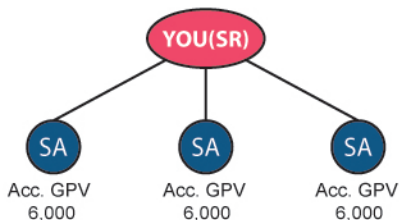

Therefore:
YOU are qualified to receive the One Time Hand Phone Cash Incentive amounting to RM1,050.

9. One Time Overseas Trip Cash Incentive

EXAMPLE

After you have 5 immediate downlines who have received their Hand Phone Cash Incentive, then you are qualified for this One Time Overseas Trip Cash Incentive.

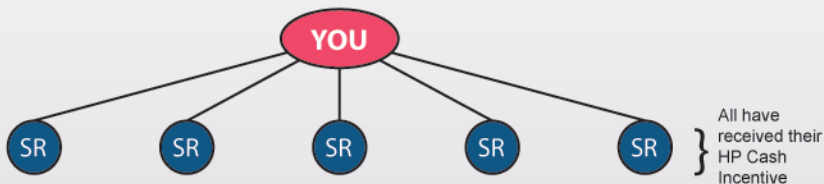

Therefore:
Once YOU have fulfilled the requirement, YOU are qualified for One Time Overseas Trip Cash Incentive amounting to RM7,000.

Assumption:-

- * Personal Sales for each distributor is 100PPV per month.
- * Each distributor sponsors 3 new distributors in each month.
- * 1PV = 1SV

1st Month

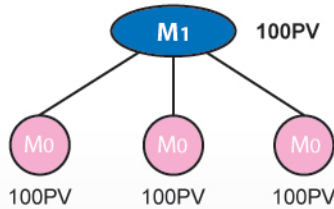

Your status : Distributor - 400PGPV (9%)

Personal PV/SV (PPV/ PSV) = 100PV/SV
Personal Group PV/SV (PGPV/ PGSV) = 400PV/SV
Accumulated PGPV = 400PV

Your Bonus Income
Group Bonus = 400SV X 9% = RM36
Less: Downlines Bonus = (3 X 100SV X 6%) = (RM18)
YOUR Bonus Income RM18

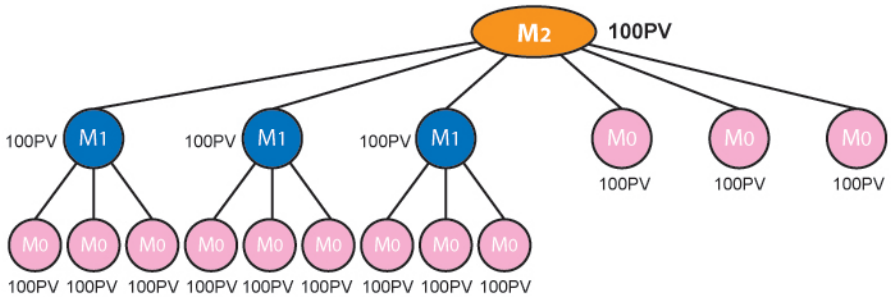

Your status: Distributor - Accumulated 2,000 PGPV (15%)

Personal PV/SV (PPV/PSV) = 100PV/SV
 Personal Group PV/SV (PGPV/PGSV) = 1,600PV/SV
 Accumulated PGPV b/f = 400PV
 Accumulated PGPV c/f = 2,000PV

Your Bonus Income

Group Bonus = 1,600SV X 15% = RM240
 Less: Downlines Bonus = (400SV X 9% X 3) + (100SV X 6% X 3) = (RM126)

YOUR Bonus Income RM114

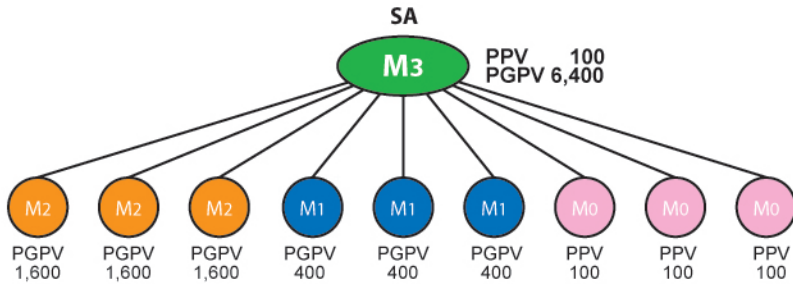

Congratulations! You have reached 4,500 Accumulated PGPV and you are now a Star Agent.

Personal PV/SV (PPV/ PSV) = 100PV/SV
 Personal Group PV/SV (PGPV/ PGSV) = 6,400PV/SV
 Accumulated PGPV b/f = 2,000PV
 Accumulated PGPV c/f = 8,400PV

Your Bonus Income

Group Bonus = 6,400SV X 25% = RM1,600
 Less: Downlines Bonus = (1,600SV X 15% X 3) + (400SV X 9% X 3) + (100SV X 6% X 3) = (RM 846)

YOUR Bonus Income RM 754

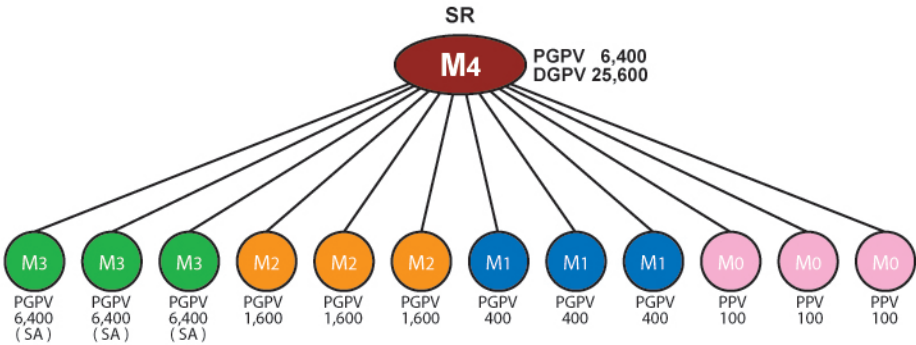

Congratulations! You have successfully promoted 3 direct Star Agent under you, and therefore you are now a Star Ruby.

Personal PV/SV (PPV/PSV) = 100PV/SV
 Personal Group PV/SV (PGPV/PGSV) = 6,400PV/SV
 Diamond Group PV/SV (DGPV/DGSV) = 25,600PV/SV

Your Bonus Income

Group Bonus	= 25,600SV X 31%	= RM7,936	
Less: Downlines Bonus	= (6,400SV X 25% X 3) + (1,600SV X 15% X 3) + (400SV X 9% X 3) + (100SV X 6% X 3)	= (RM5,646)	RM2,290
Development Bonus	= 6,400SV X 5% X 3	=	RM 960
HP Cash Incentive			RM1,050
YOUR Bonus Income			RM4,300

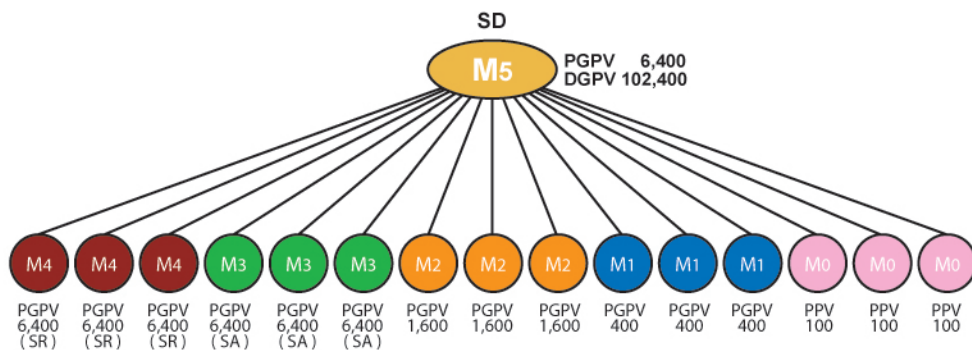

Congratulations! You have successfully promoted 6 SA (1st Generation) and have also met the 5,000DGPV quota. Hence you are now a Star Diamond.

Personal PV/SV (PPV/ PSV) = 100PV/SV
 Personal Group PV/SV (PGPV/ PGSV) = 6,400PV/SV
 Diamond Group PV/SV (DGPV/ DGSV) = 102.400PV/SV

Your Bonus Income

(A) Star Group Bonus = 102,400SV X 37% = RM37,888
 Less: Downlines Bonus = (25,600SV X 31% X 3) + (6,400SV X 25% X 3) + (1,600SV X 15% X 3) + (400SV X 9% X 3) + (100SV X 6% X 3) = (RM29,454) **RM 8,434.00**

(B) Development Bonus
 1st Level = 6,400SV X 6 X 5% = RM 1,920
 2nd Level = 6,400SV X 9 X 4% = RM 2,304 **RM 4,224.00**

(C) International Profit Sharing
 Assumption:-
 i) IPS Fund = RM40,000
 ii) Total IPS Point for all Qualifiers = 5,000,000pts
 iii) YOUR IPS Point for the month = 102,400SV X 100% = 102,400 pts

Your International Profit Sharing
 = RM40,000 X $\frac{102,000 \text{ pts}}{5,000,000 \text{ pts}}$ = **RM 819.20**

YOUR Bonus Income RM13,477.20

One World
One Market

www.dxn2u.com



DXN MARKETING SDN. BHD.

BLOCK C, 8 SURIA BOUTIQUE OFFICES, JALAN PJU 1/42, DATARAN PRIMA, 47301 PETALING JAYA,
SELANGOR DARUL EHSAN, MALAYSIA

TEL : 603-7809 3388 FAX : 603-7809 3200